

Difficult Installation

Face Fixing Onto Walls

The bolts should be through both flanges of the fence post. A spacer tube 50mm long is used between the flanges. The spacer can be cut from galvanised water pipe or supplied on request by the factory.

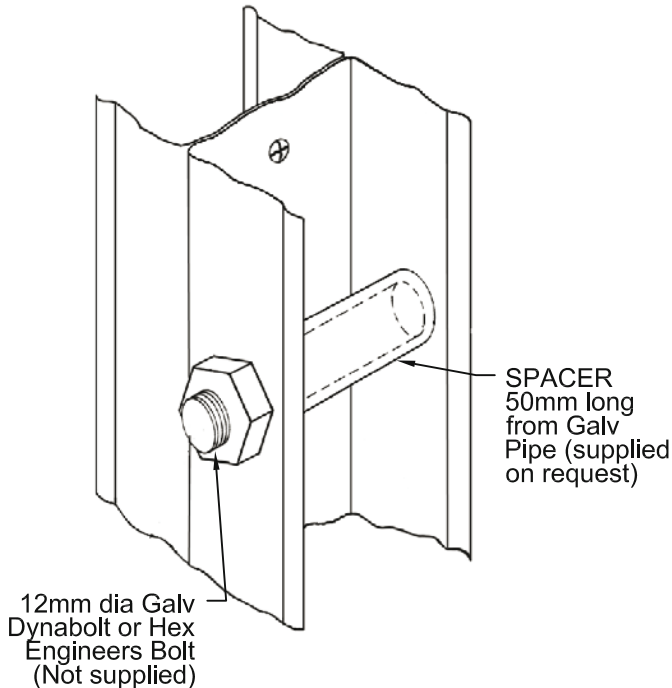

Nogging for Timber Decks

When bolting down onto the top of timber decks, the coach screws must go into a solid joist or solid block nogg fixed between joists. Coach screwing into deck timber only is neither acceptable nor is it safe..

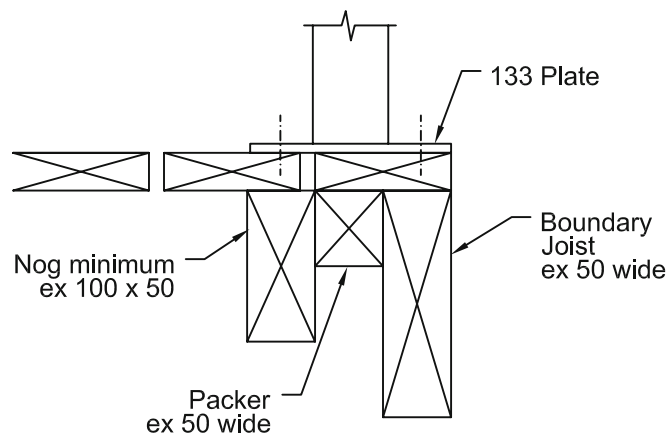

Bolting on Top of Concrete, Block Walls and Decks

For bolting on top of concrete, block walls and decks, special bolt down feet are available. The bracket slips up inside fence the post between the bottom rail and the fence post. Small feet for fences up to 1.2 metres, large feet for higher fences.

